

# INSTALLATION INSTRUCTIONS

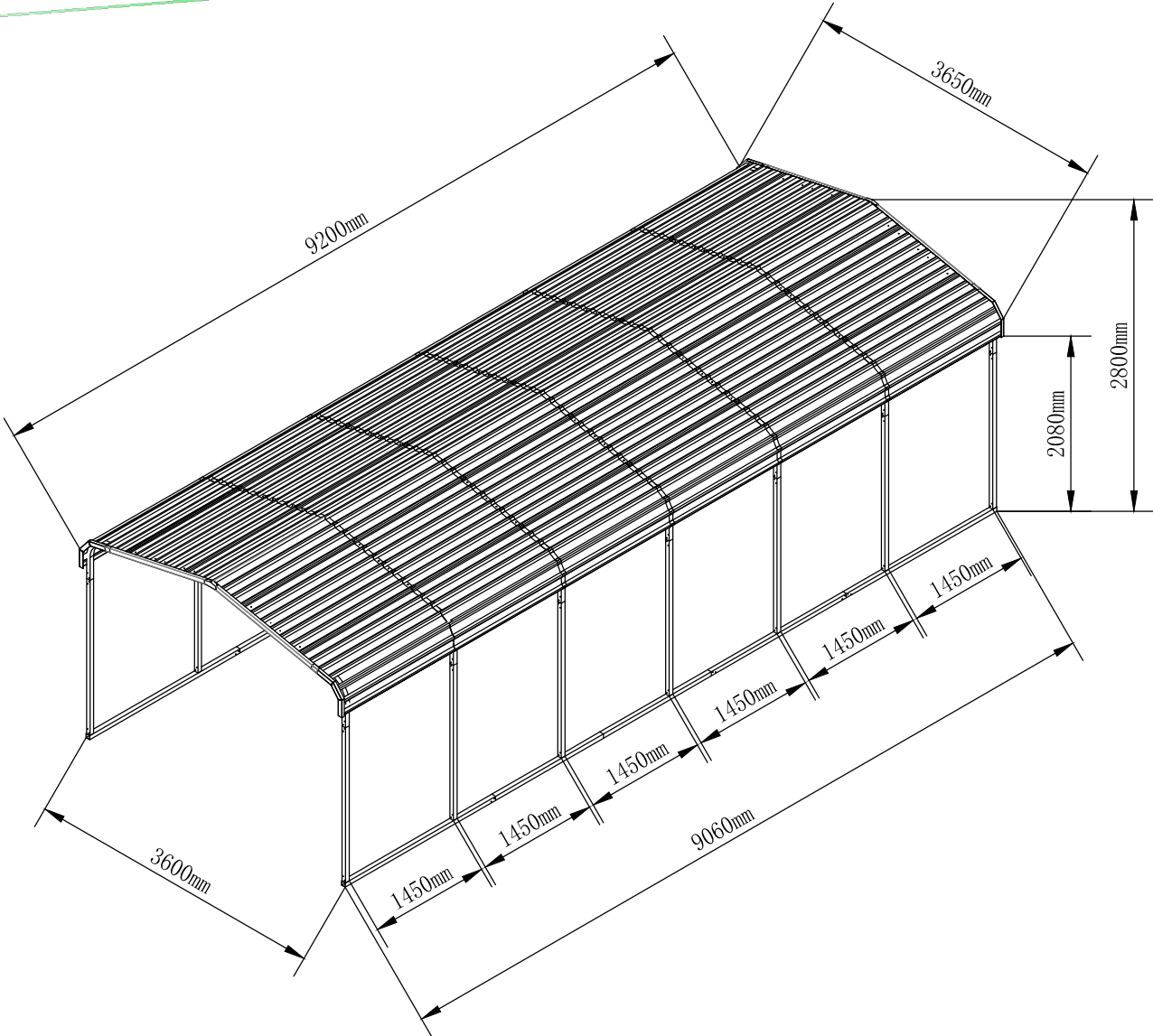





MODEL:SGC1230

## STEEL CARPORT

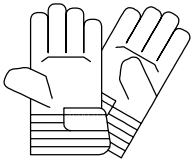

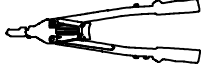
# BEFORE YOU START

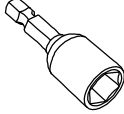
## Items Required:

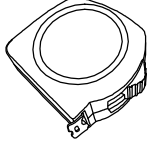
Safety Gear				
	gloves	Safety Glasses	Shoes	Riveting Gun
Tools				
	Power drill	Sleeve	Pencil	Tape Measure

- Clear a working area to allow access on 4 sides. A raised work surface will make assembly easier.
- Please choose a dry and calm day to start assembly. Do not attempt installation in rainy or windy day.
- **Keep roof clear of leaves and snow with long handled, soft-bristled broom. Heavy amounts to snow on roof can damage building, making it unsafe to enter.**
- All parts are identified so when working through the instructions page by page the diagrams show where each part is positioned.
- Before starting, to avoid any accidental injury, we recommend the use of gloves to protect your hands, safety glasses to protect your eyes and shoes or boots to protect your feet.
- Many of the holes have been pre-punched, to allow fixing using self-tapping screws or rivets, where additional holes are required a drill bit is included.
- Please keep children away from your construction site.
- Most assembly can be completed by one person, assistance may be needed when you reach the erection stage.
- Cleaning should be performed as often as is required to remove any dirt, salt, and pollutants.
- Please note: Some local government authorities have rules & regulations on shed installation and you may need approval to erect this shed.







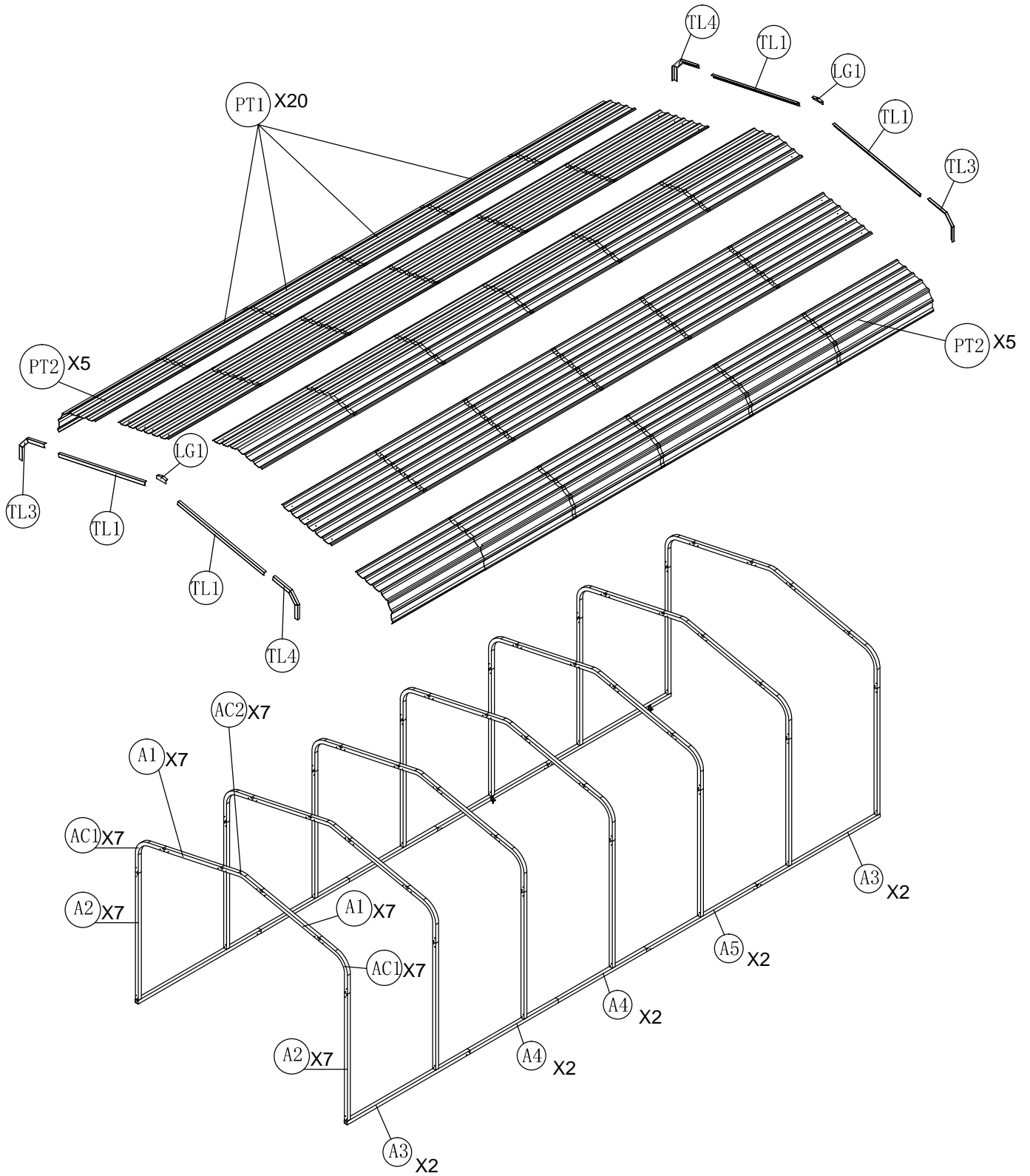





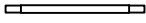
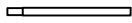

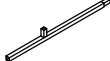
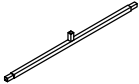
### STEPS:

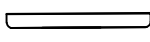
1. Unpack all components from the carton and lay outside your work area and check parts against the part list on the next page.
2. Work through assembly instructions Page by Page
3. When completed place shed in position and anchor securely to the ground.
4. Clean up all metal pieces, rivets and screws.

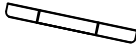
# FRAME ASSEMBLY

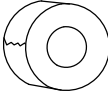

# PART LIST

Picture	Name	QTY	Check	Picture	Name	QTY	Check
	PT1	20			PT2	10	
	A1	14			A2	14	
	A3	4			A4	4	
	A5	2			AC1	14	
	AC2	7			TL1	4	
	TL3	2			TL4	2	
	S12	456			C72	12	
	S11	12			L5	4	
	LG1	2			Waterproof tape	5	

# FRAME ASSEMBLY

STEP 1

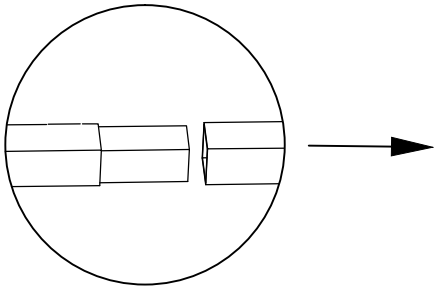

STEP 2

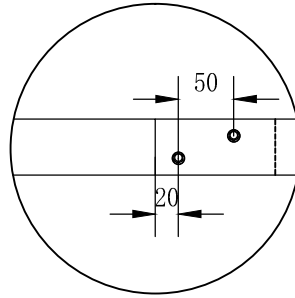



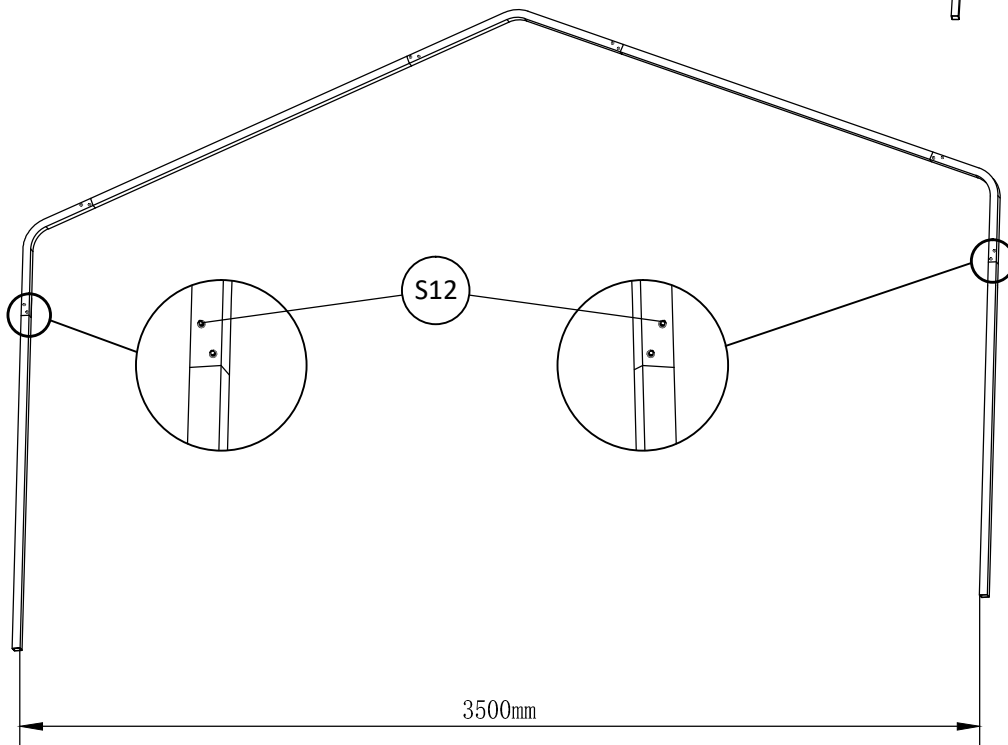
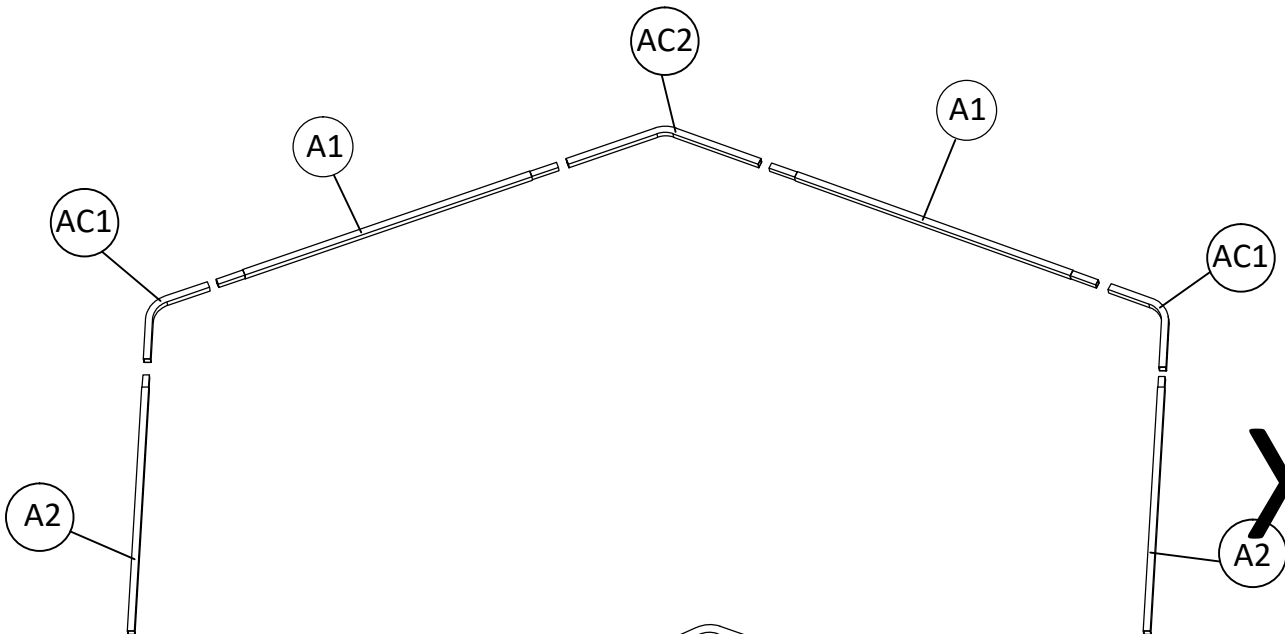

	A2	14		AC1	14		A1	14		AC2	7
	S12	168									

PART A



# FRAME ASSEMBLY

	A3	4		A4	4		A5	2		S12	32
---	----	---	---	----	---	---	----	---	---	-----	----

STEP 1

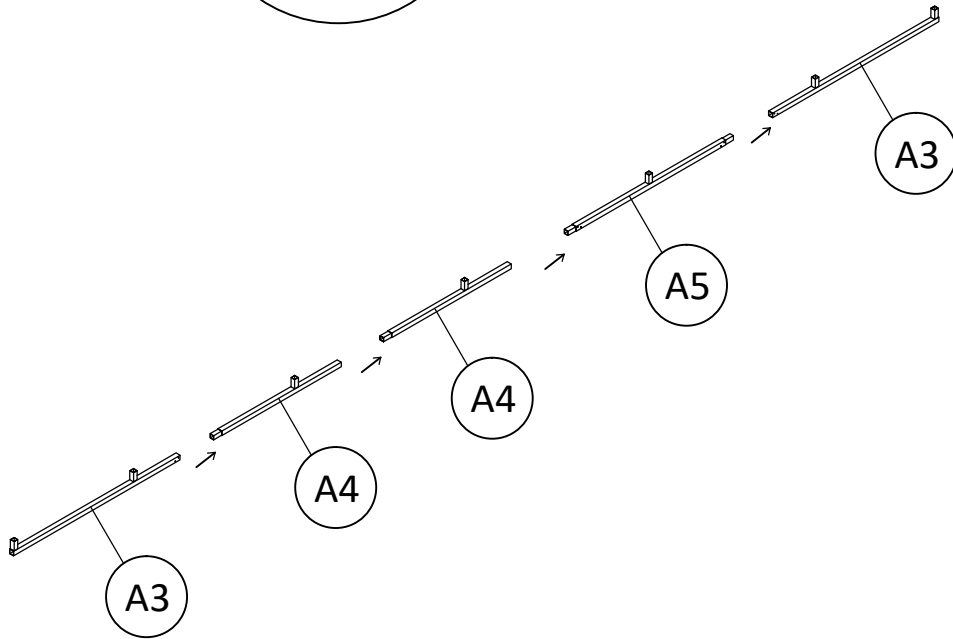
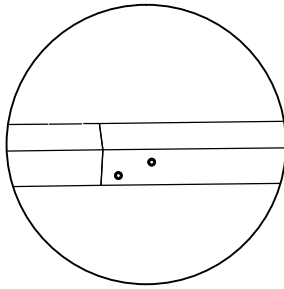
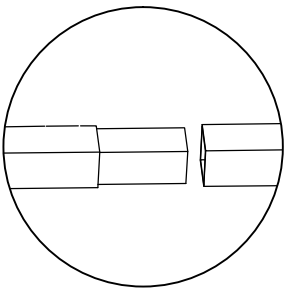

STEP 2

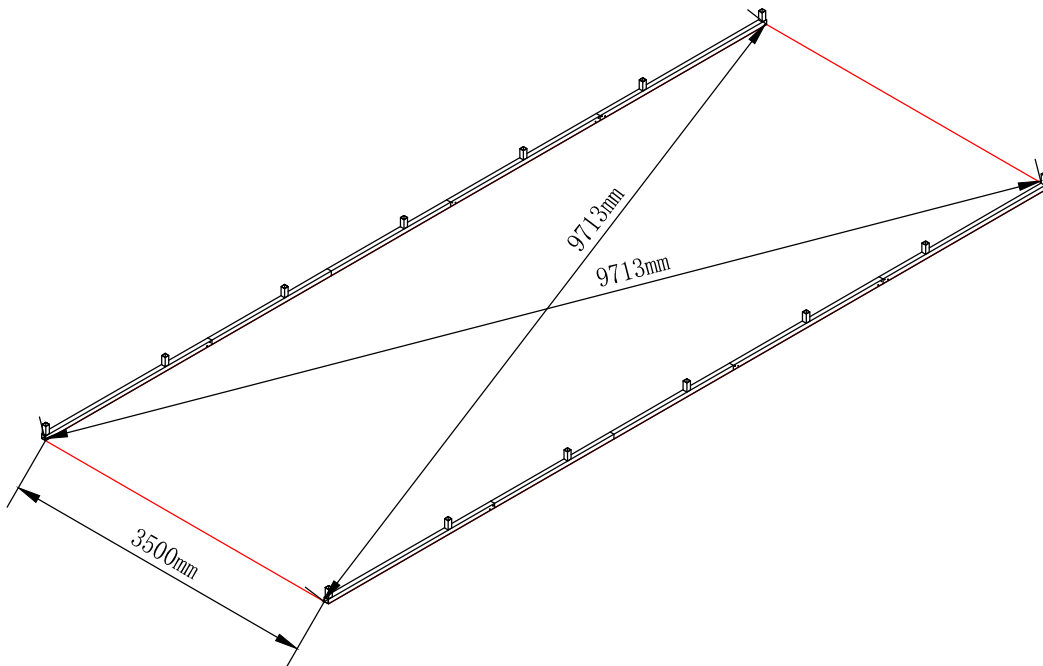

X2





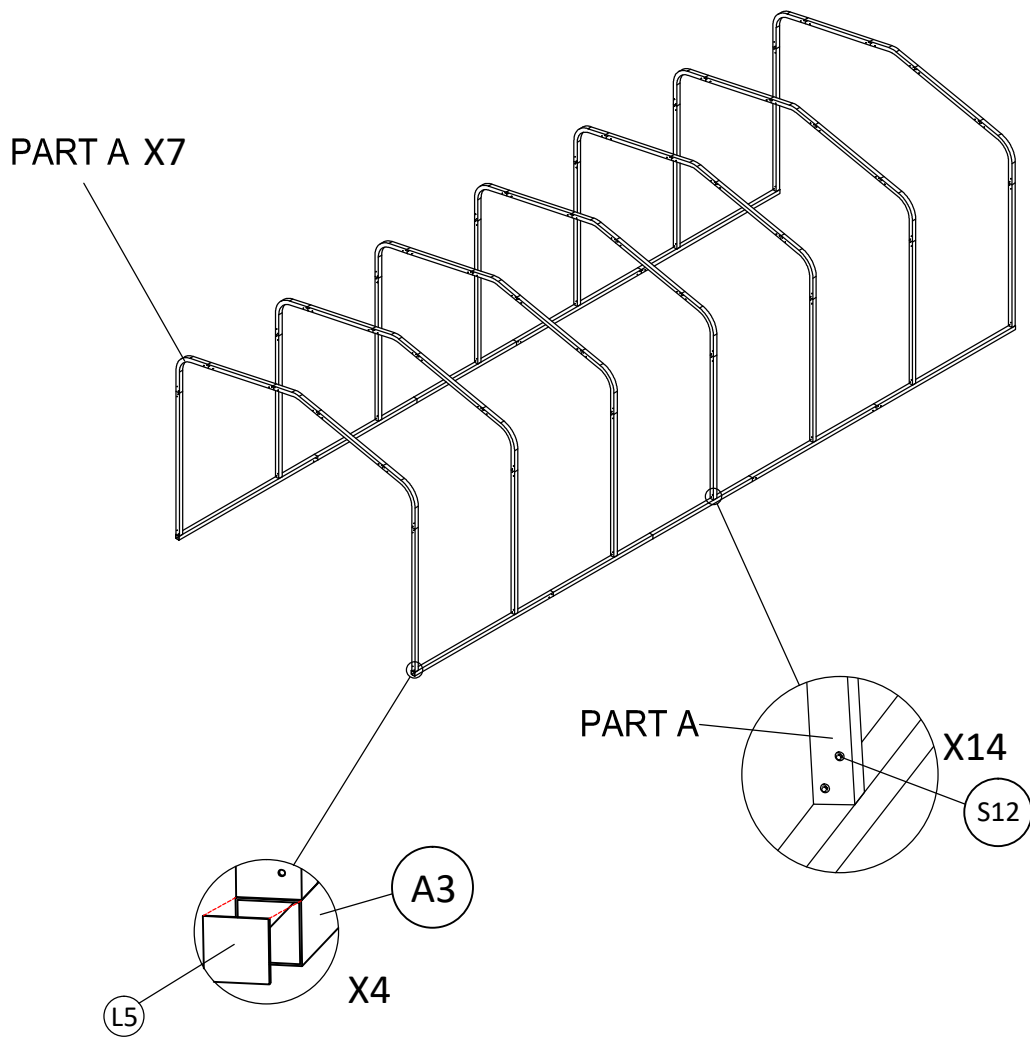

# FRAME ASSEMBLY

	S12	56		L5	4
---	-----	----	---	----	---



# FRAME ASSEMBLY

	PT1	4		PT2	2		S12	28		Waterproof tape
---	-----	---	---	-----	---	---	-----	----	--	-----------------

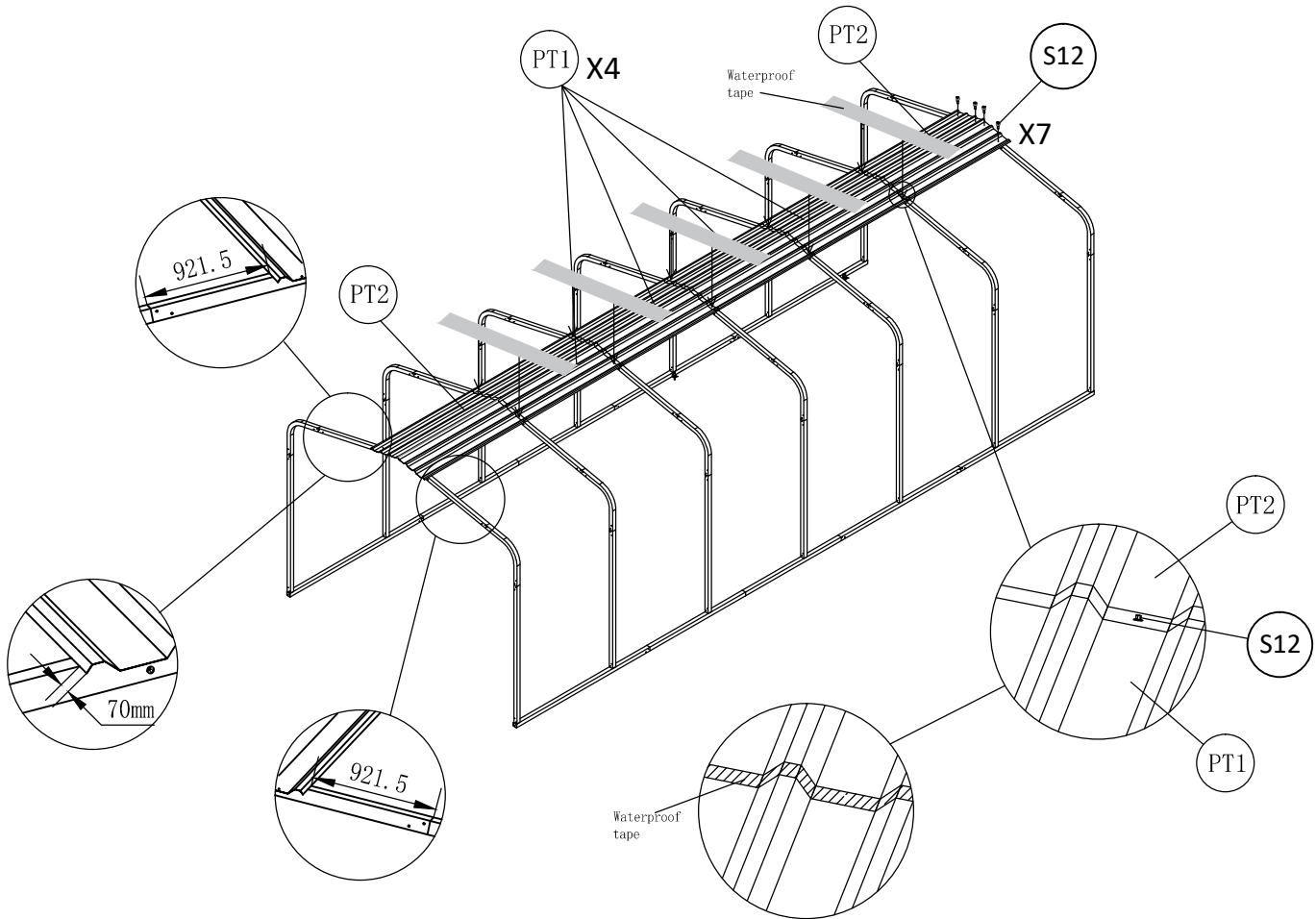



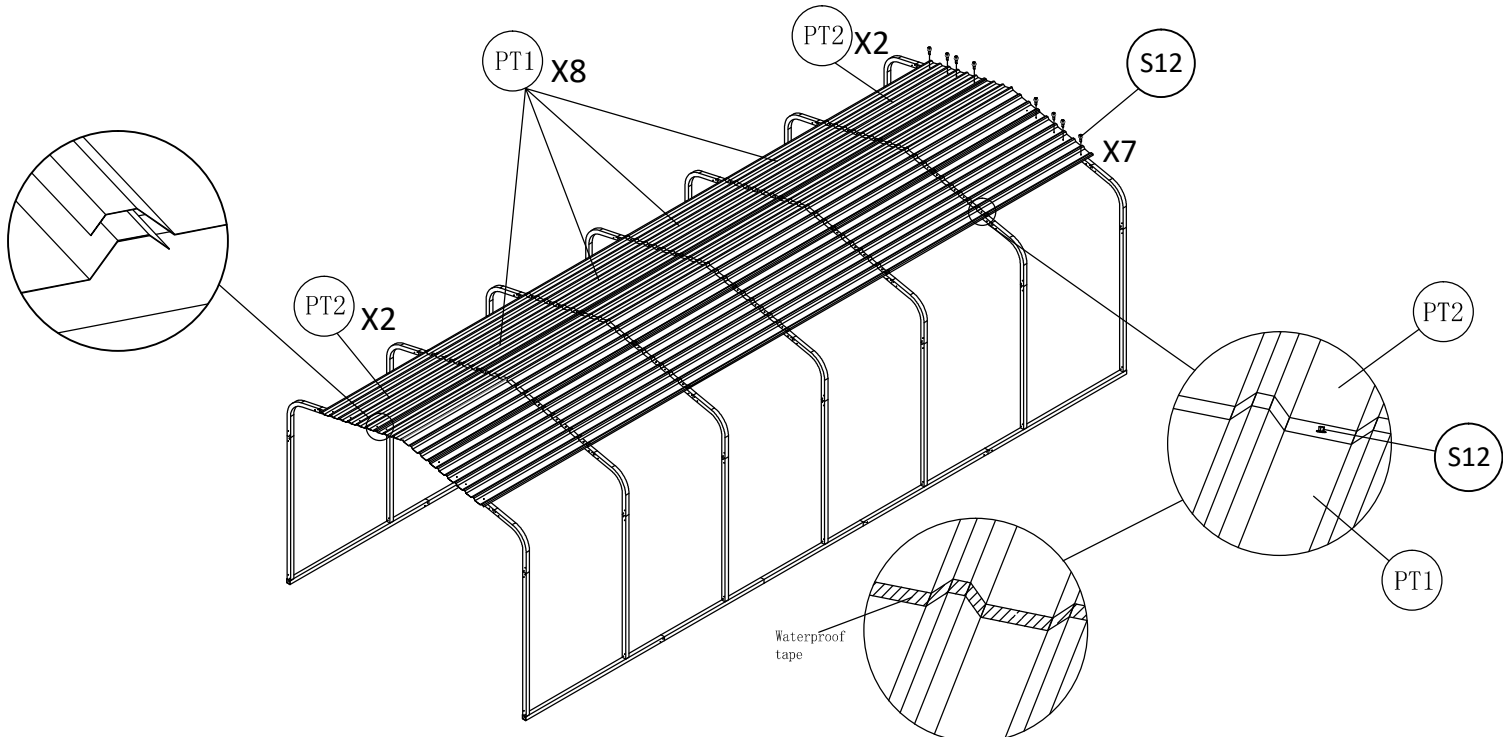

	PT1	8		PT2	4		S12	56		Waterproof tape
---	-----	---	---	-----	---	---	-----	----	---	-----------------





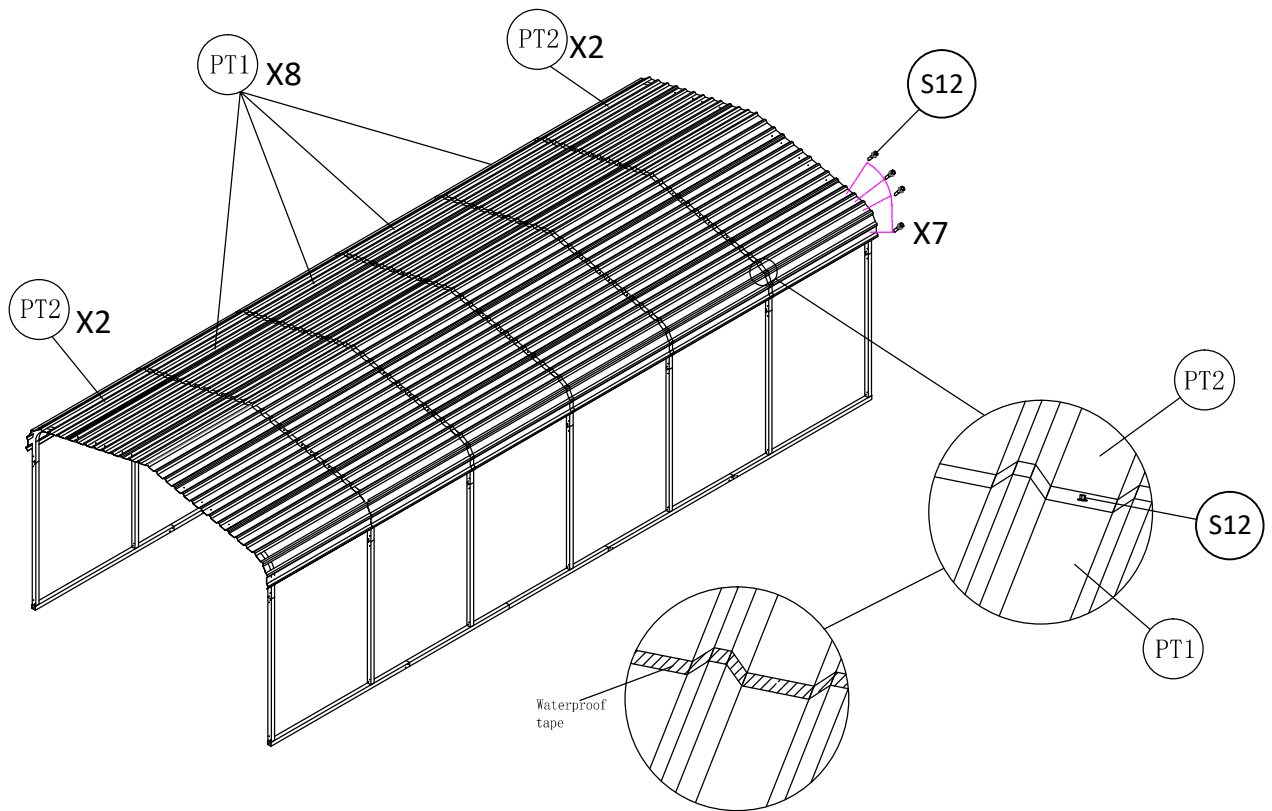

# FRAME ASSEMBLY

	PT1	8		PT2	4		S12	56		Waterproof tape
---	-----	---	---	-----	---	---	-----	----	--	-----------------



NOTED: Both end of Panels PT1 have holes, Please noted the short holes space are connect with Panels PT2.

# FRAME ASSEMBLY

	S11	12		C72	12		S12	36
---	-----	----	---	-----	----	---	-----	----

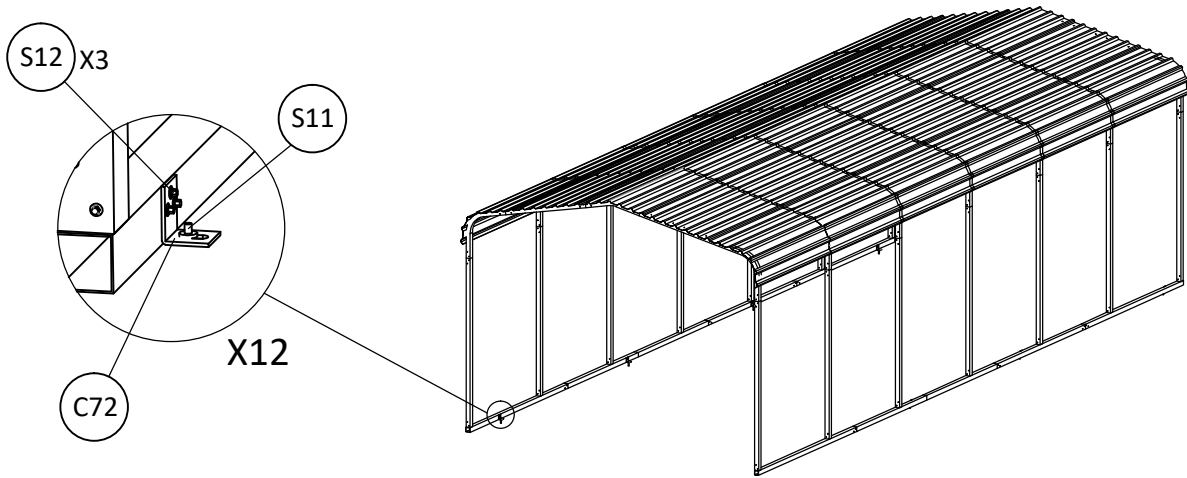

# ANCHORING CONSTRUCTION

Right Wall

9060mm

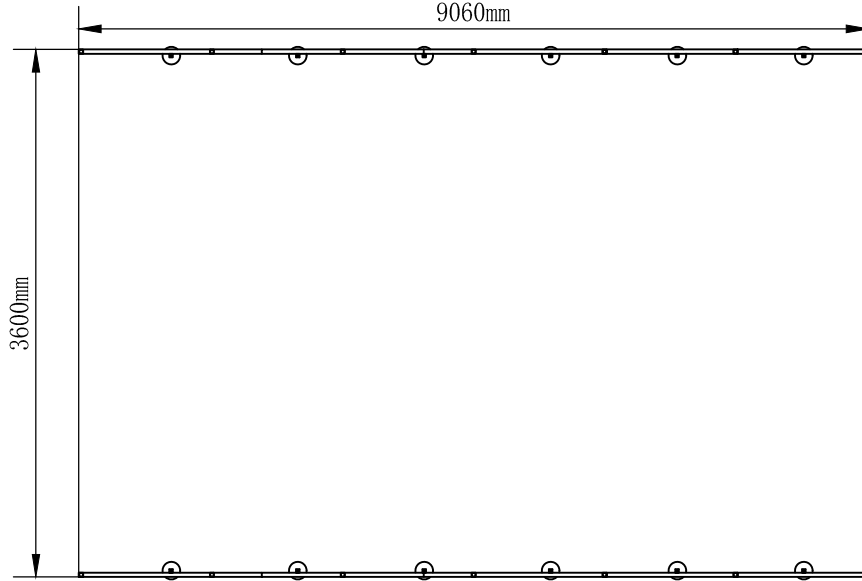

Front Wall

3600mm

Back Wall

Left Wall



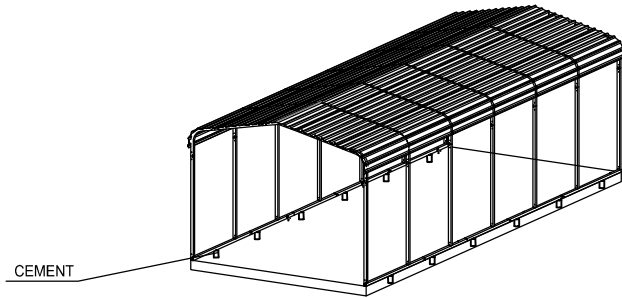
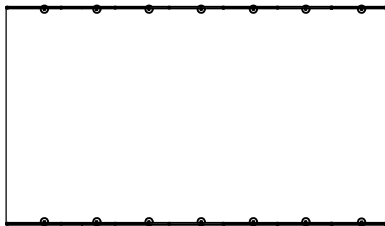

## ANCHORING OF CARPORT

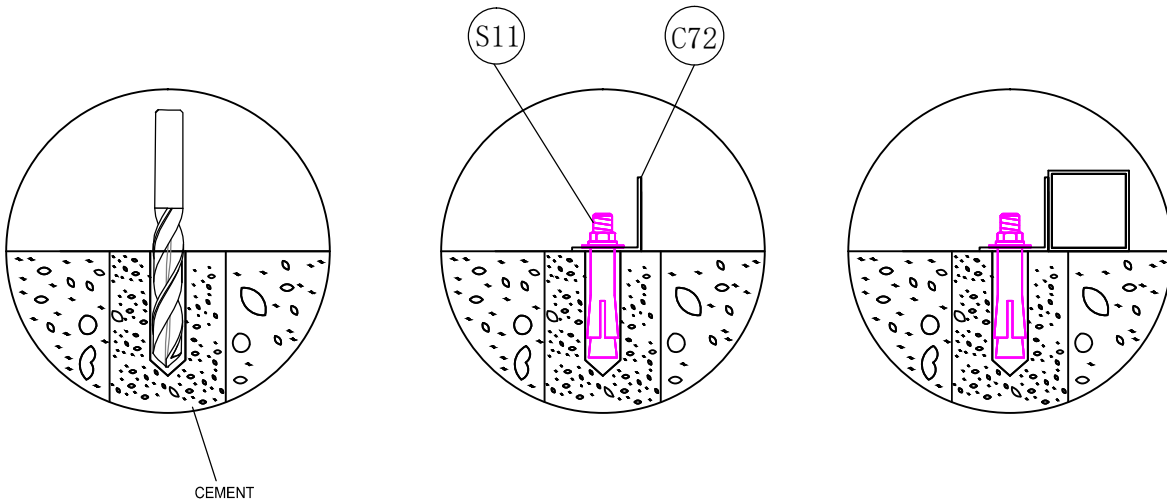

## ANCHORING INSTALLATION INSTRUCTION



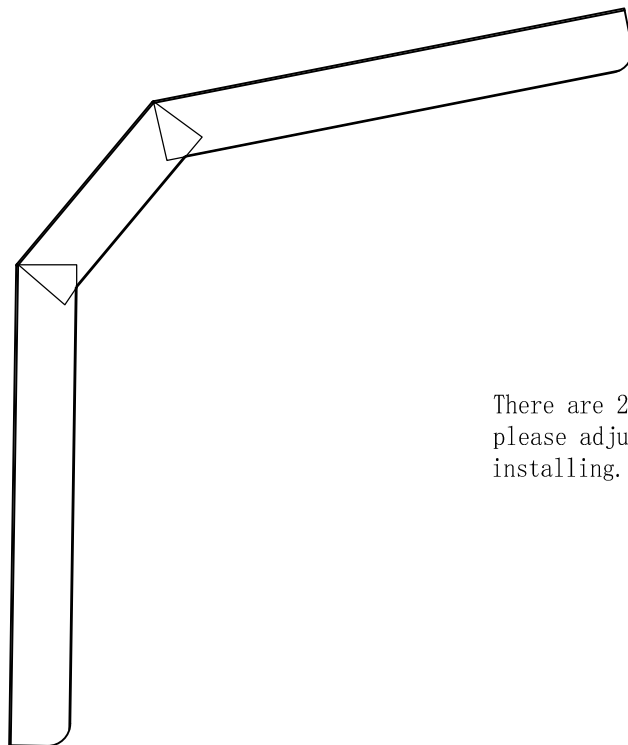
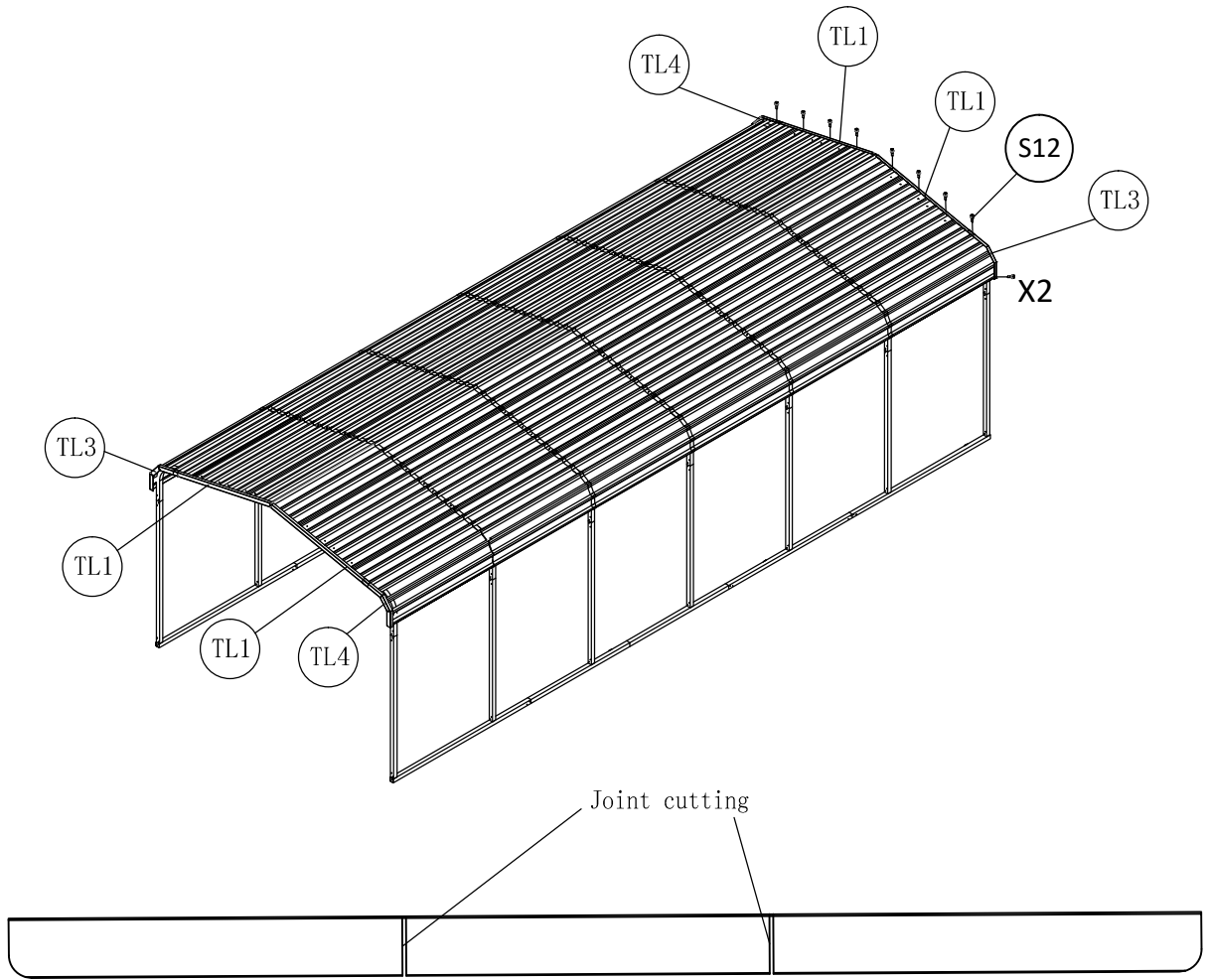

# FRAME ASSEMBLY

	TL1	4		TL3	2		TL4	2		S12	20
---	-----	---	---	-----	---	---	-----	---	--	-----	----



There are 2 joint-cutting on the TL3 and TL4, please adjust the proper Angle when you installing.

# FRAME ASSEMBLY

	LG1	2		S12	4
---	-----	---	---	-----	---

